

# 150 CL. CAST STEEL FLGD.SWING CHECK VALVE

## BILL OF MATERIAL

**TECHNICAL DATA:-**

**CONSTRUCTION:-** SWING TYPE DISC.RENEWABLE SEAT RING AND BOLTED COVER.

**DESIGN&MAFRG.STD.:-** AS PER BS-1868

**INSPECTION & TESTING:-** AS PER B.S. 5146/BS-6755 Pt1

**FACE TO FACE:-** AS PER ANSI B16.10 /API 598

**END CONNECTION:-** FLANGED AS PER ANSI, B-16.5RF  
SERRATED FINISH

SR. NO	DESCRIPTION	MATERIAL	QTY.
1	BODY	ASTM A216 GR.WCB.	1
2	SEAT RING	SS410	—
3	DISC	ASTM A216 GR.WCB. 13% CR.FACING	1
4	HINGE	ASTM A216 GR.WCB.	1
5	WASHER	STEEL	1
6	LOCK NUT	STEEL	1
7	HINGE PIN	SS410	1
8	PIN BUSH	STEEL	1
9	BUSH GASKET	CAF	1
10	BODY GASKET	SW-SS304 + CAF/ GRAPHITE FILLER	1
11	COVER	ASTM A216 GR.WCB.	1
12	BODY BOLTS&NUTS	STEEL	—

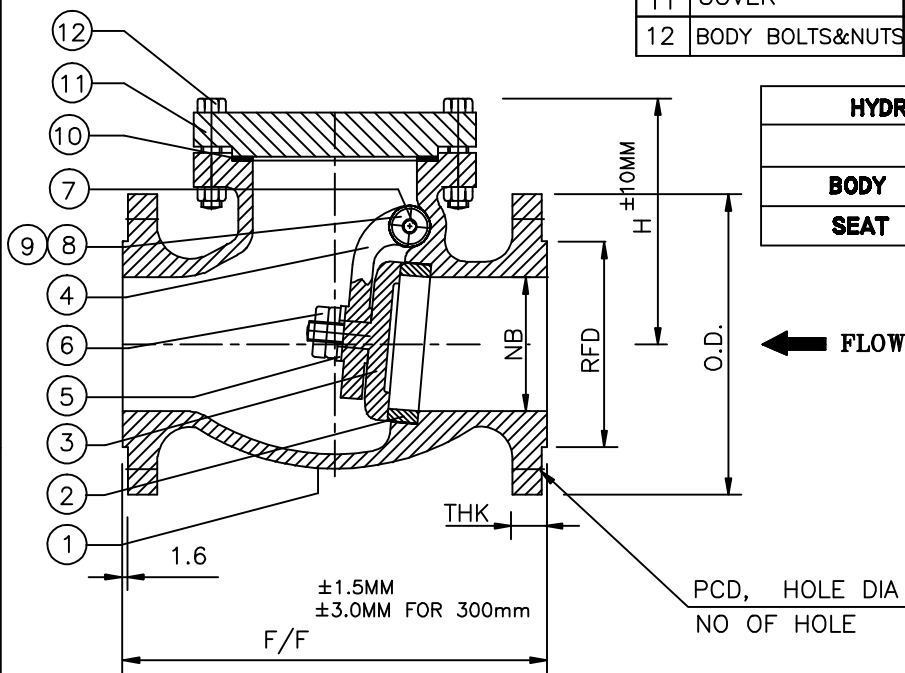

HYDRO TEST PRESSURE	
150#	
BODY	32Kg/cm2g
SEAT	22Kg/cm2g

SIZE	N.B.	F/F	H	O.D.	THK	RFD	PCD	HOLE DIA	NO OF HOLE	QTY.
50	51	203	150	152.5	16.0	92.0	120.5	19.0	4	
65	63	216	150	178.0	17.5	105.0	140.0	19.0	4	
80	76	241	175	190.5	19.0	127.0	152.5	19.0	4	
100	102	292	215	228.5	24.0	157.5	190.5	19.0	8	
150	152	356	265	279.5	25.4	216.0	241.5	22.2	8	
200	203	495	350	343.0	28.5	270.0	298.5	22.2	8	
250	254	622	380	406.5	30.0	324.0	362.0	25.4	12	
300	305	698	420	482.5	32.0	381.0	432.0	25.4	12	

<b>DATA SHEET NO:-</b>	<b>DATE:-</b>	DRN	<b>MAZHAR</b>	<b>23.5.08</b>
<b>CUSTOMER :-</b>		CHD	<b>ARNAV</b>	
<b>ENQ. NO :-</b>		APPD		
<b>OCEAN VALVES MFG. CO.</b> 10, PARMESHWAR ESTATE, PLOT-712, PH-IV, GIDC, VATVA, A'BAD.		DRAWING NO OV/SCV/150/2-12/CS		
		SHEET OF		